

1SP11-01-032

DIN 7982
4,8 x 13
20x

1

1SZ12-03-021

20x

2

1SZ12-01-015

6x

4

1SP11-01-019

DIN 7976
6,3 x 38
6x

5

1SZ12-04-003

1x

8

1SP01-01-016

Ø8 x 80
140x

9

1SZ12-03-008

4x

10

1SZ18-01-097

18x

82

1SP07-01-014

Ø4x8
36x

83

1SZ12-03-001

5x

84

1SZ15-01-004

8x

85



2Z01-01-SD008

3230 mm
2x
43

2Z01-01-SD009

3080 mm
2x
44

2Z01-01-SD017

3080 mm
2x
45

2Z01-01-SD005

3230 mm
2x
46



2Z01-01-SD009

D
3230 mm
2x
47

2Z01-01-SD002

3230 mm
30x
48

2Z01-01-SD022

1040 mm
10x
49

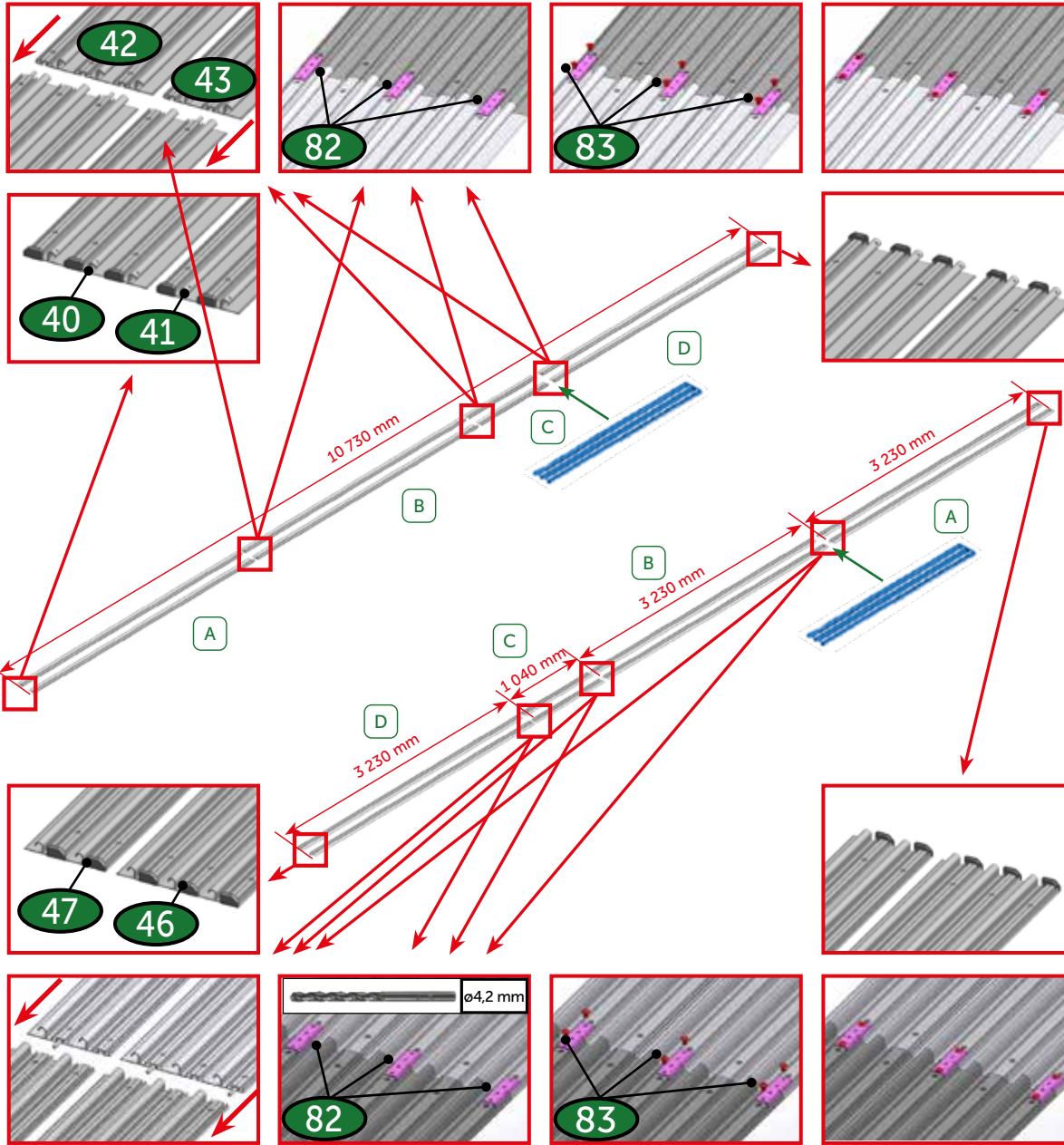

OPTIONAL

Prodloužení kolejí
 Rail extension
 Schienenverlängerung
 Prolongement de rails
 Ríales prolongados
 Продолжение рельсов

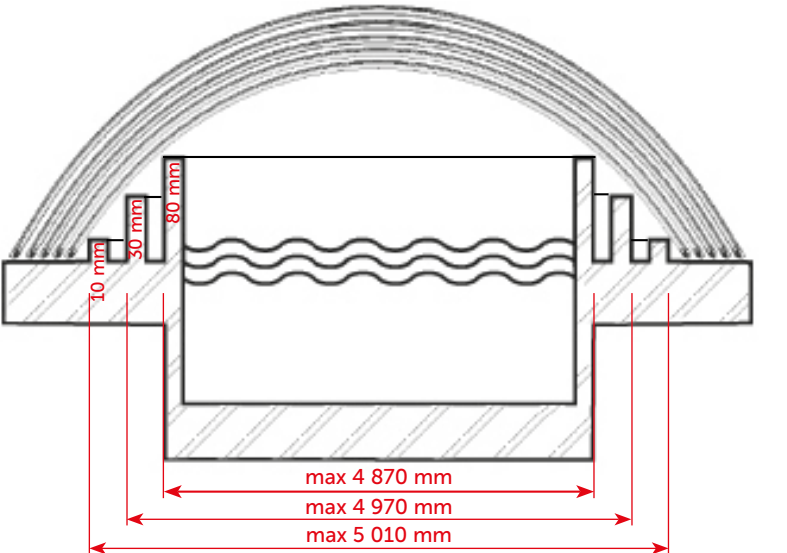
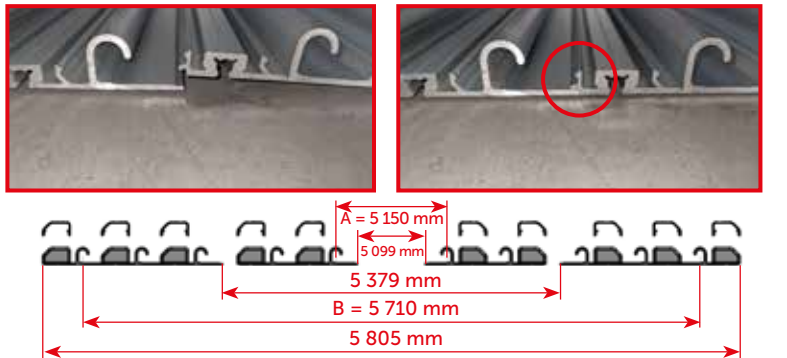

2x	40	2x	43	2x	44	2x	46
2x	41	2x	42	2x	45	2x	47

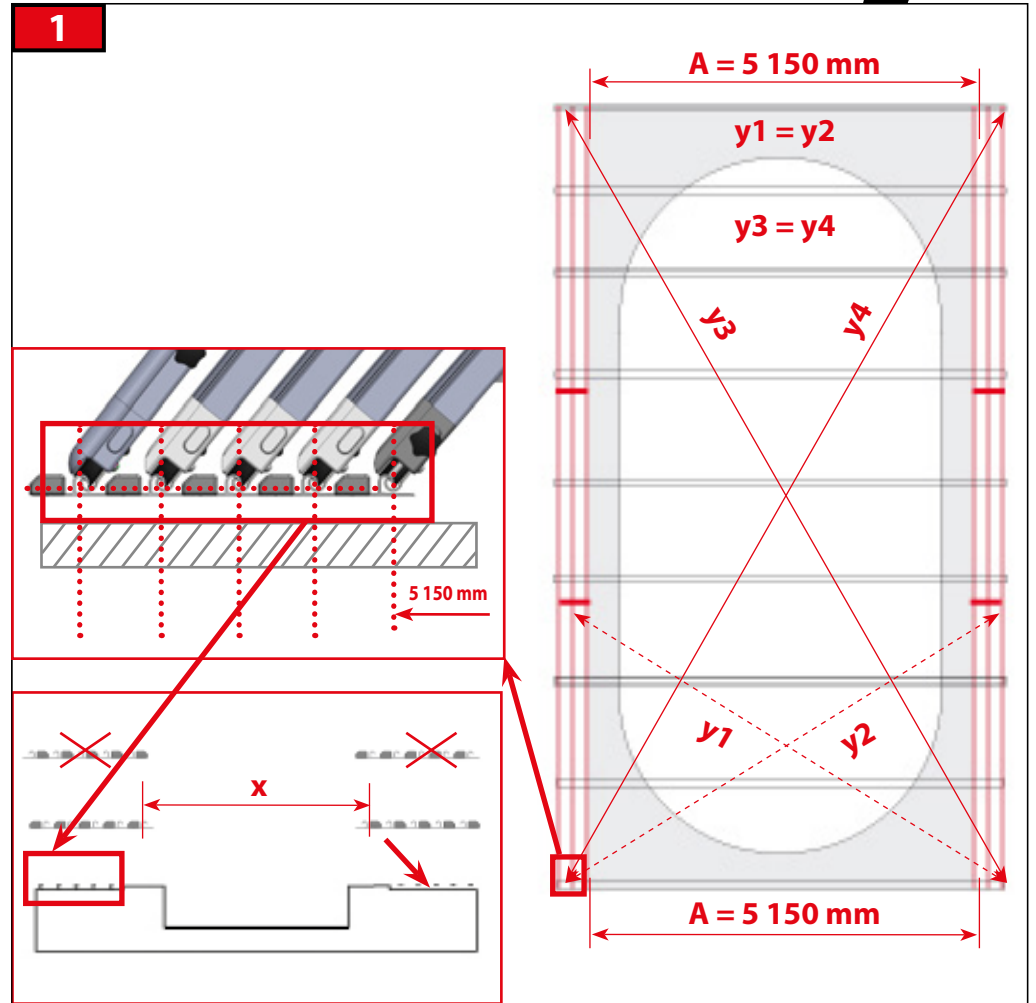
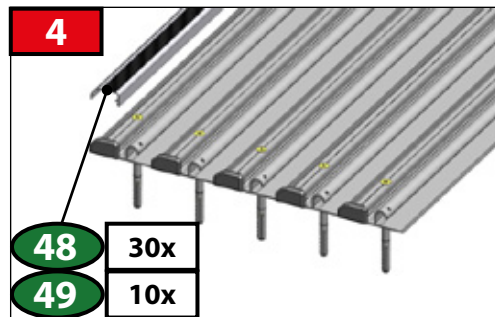
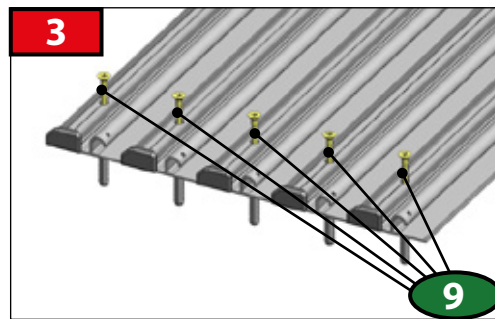
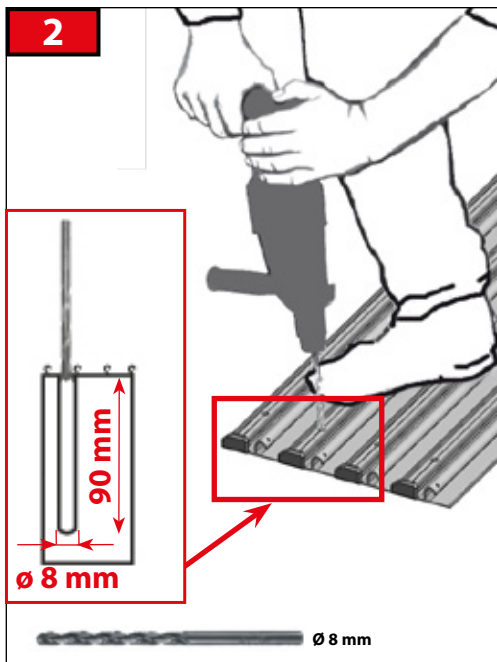
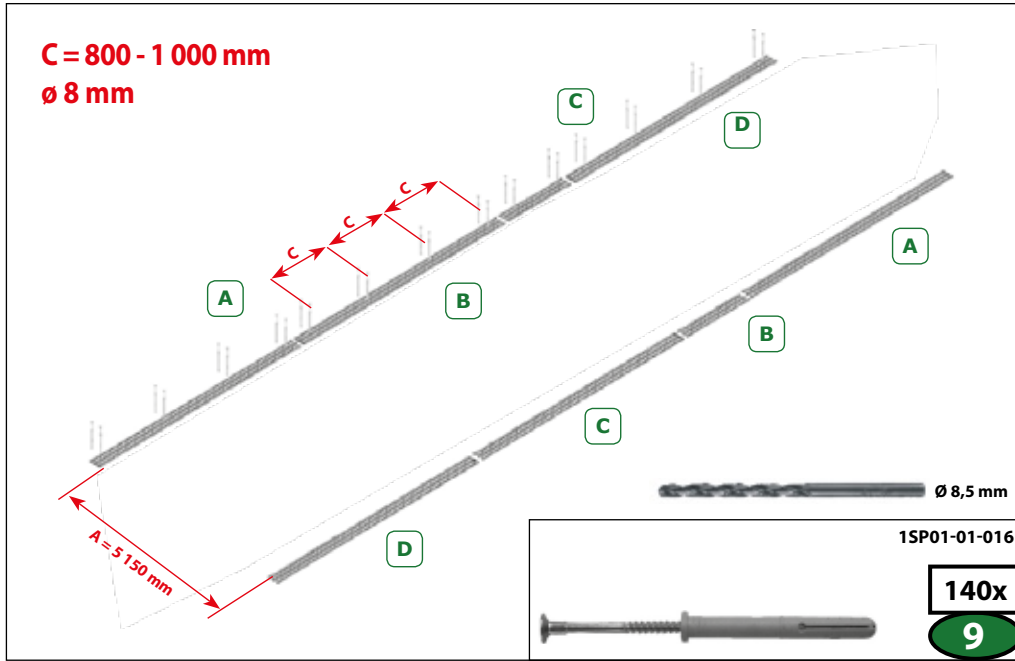

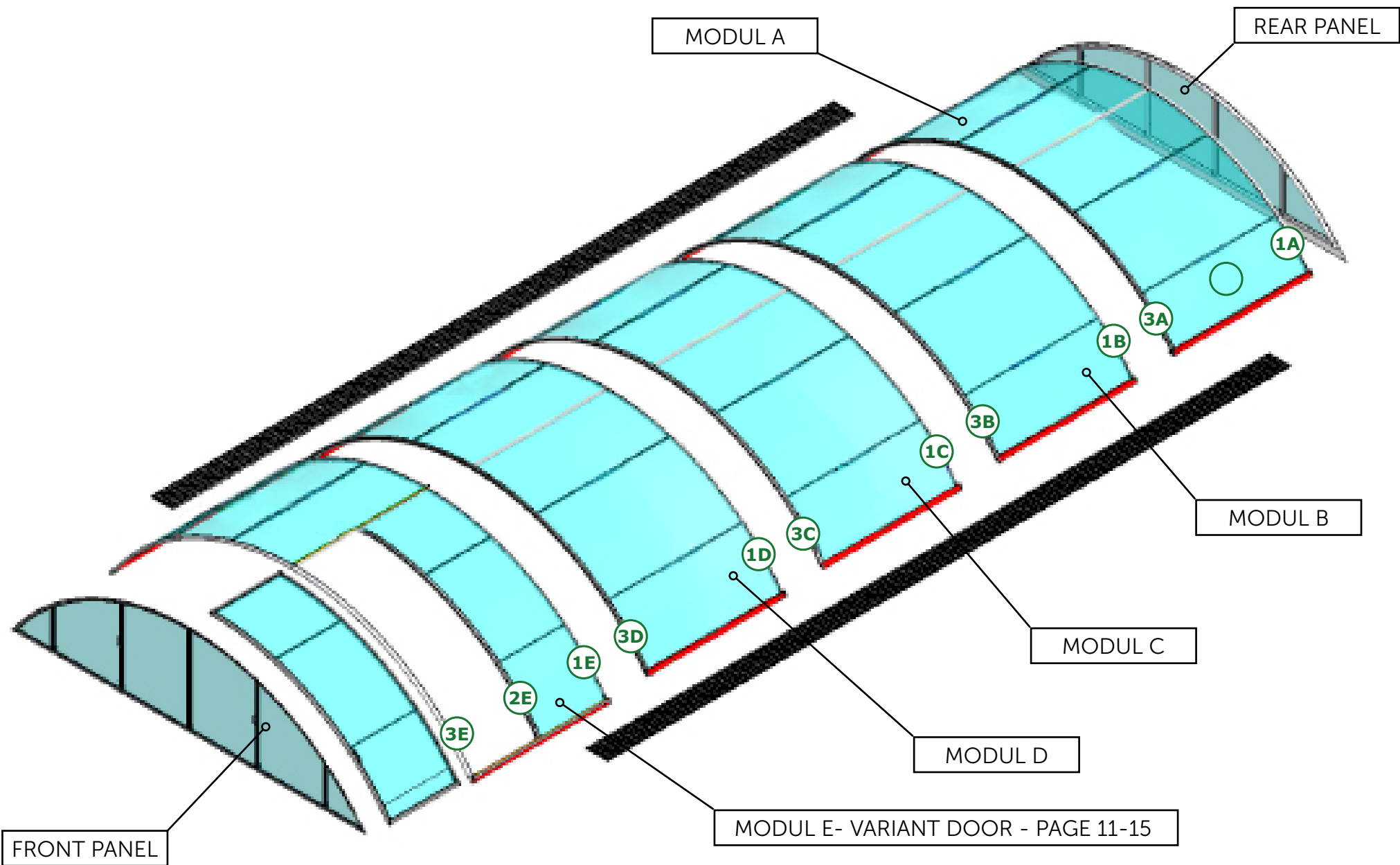

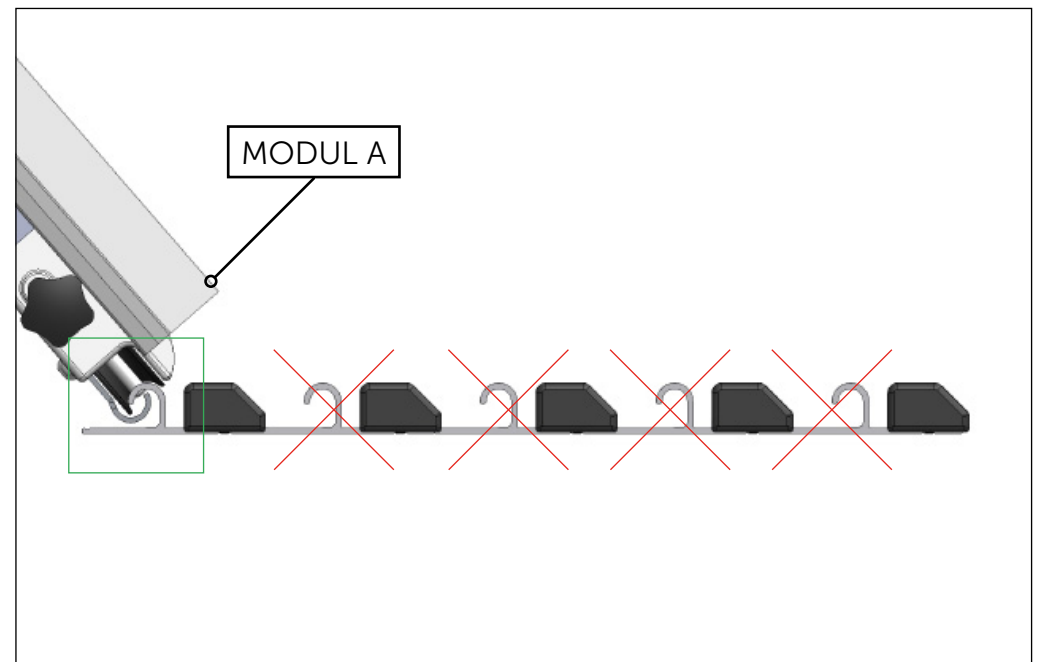
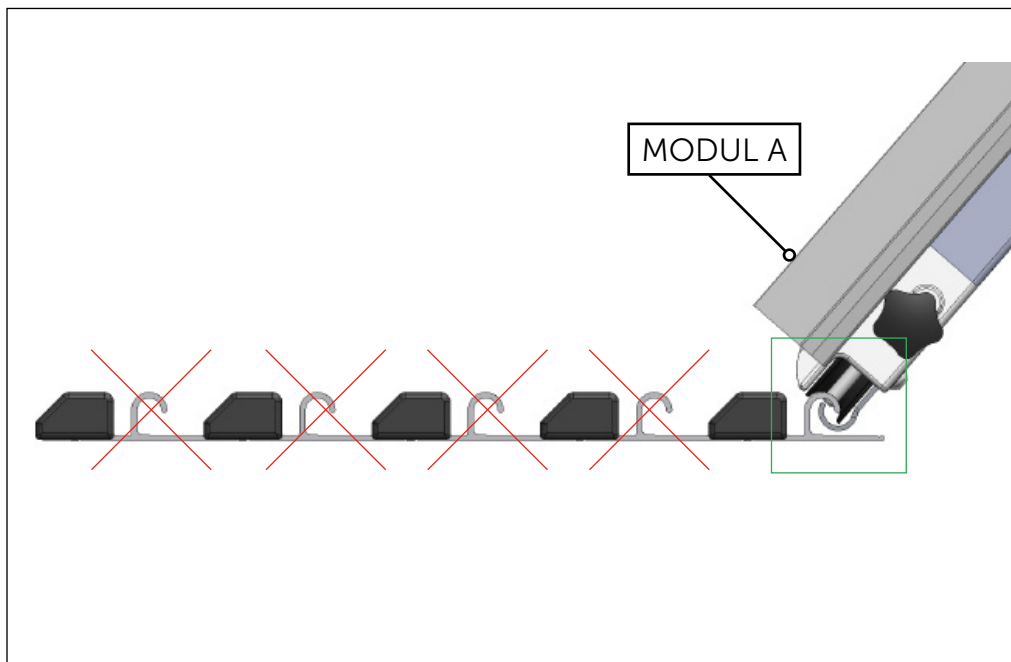
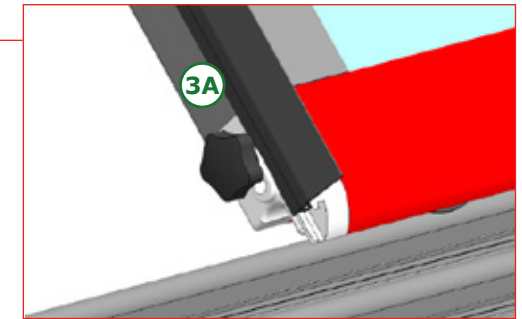
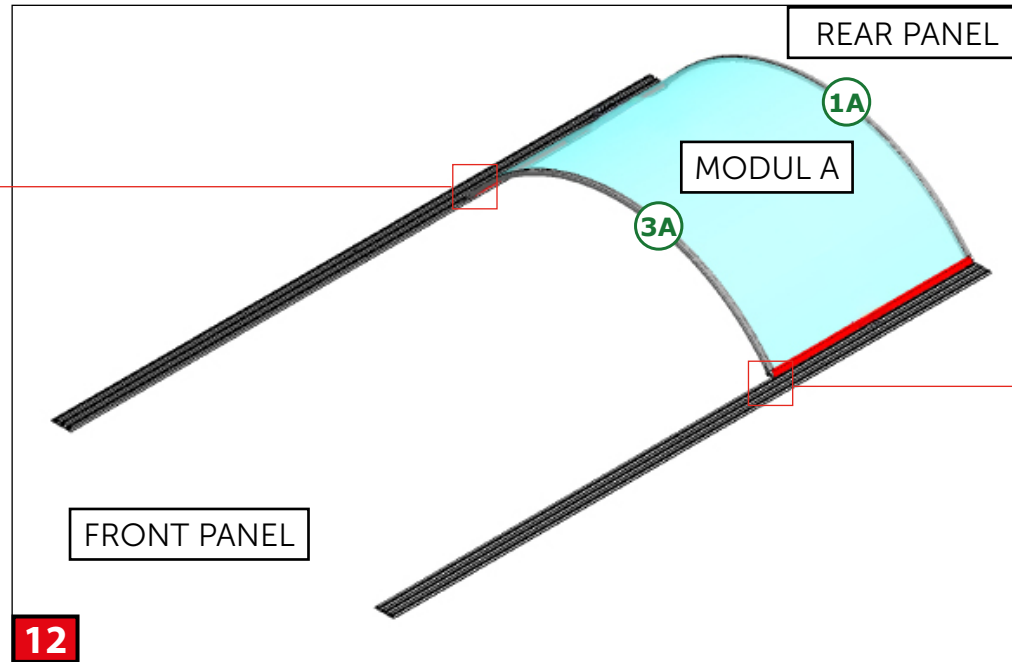
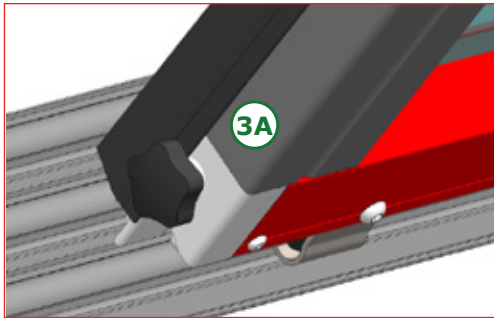

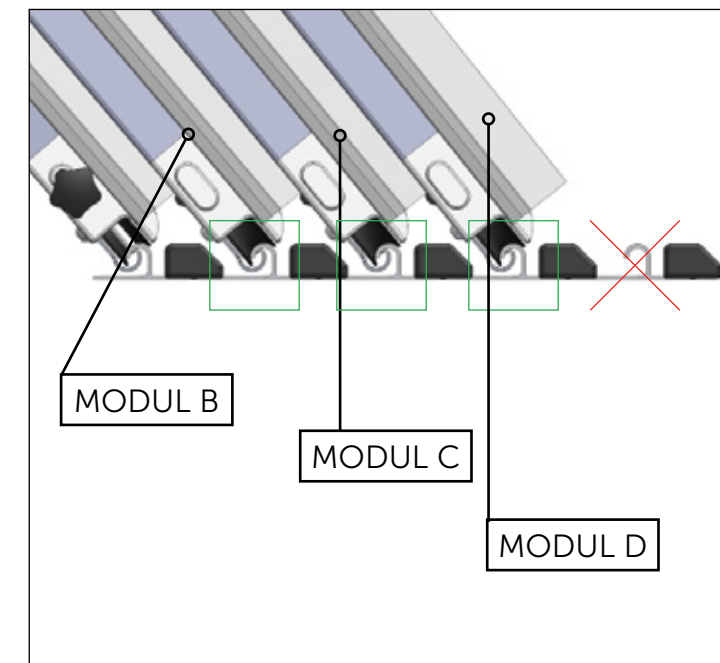
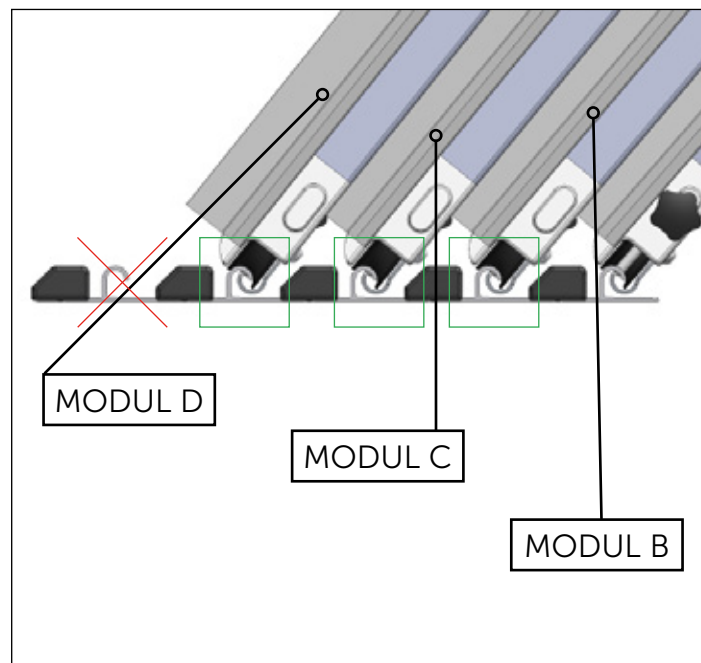
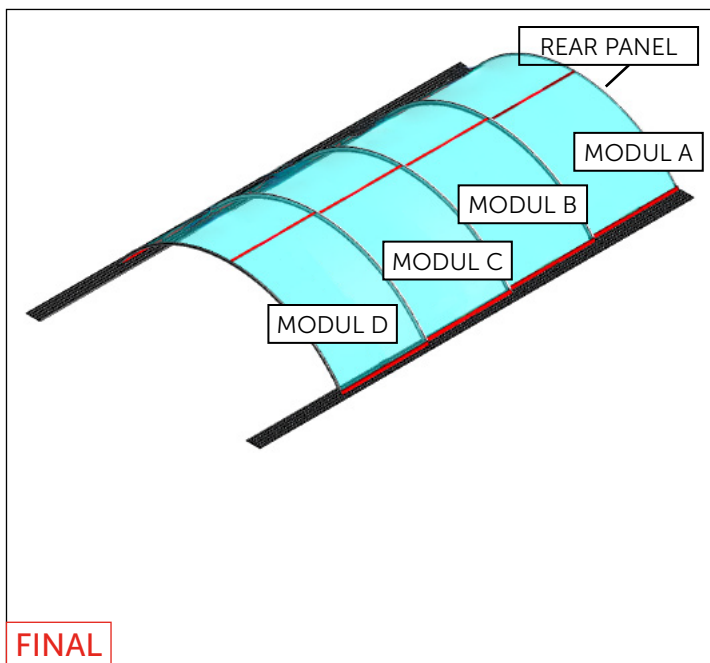
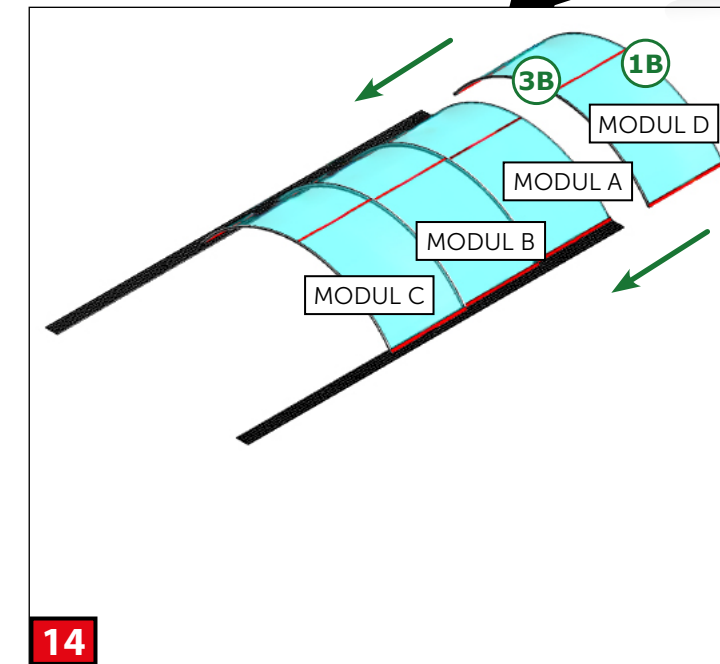
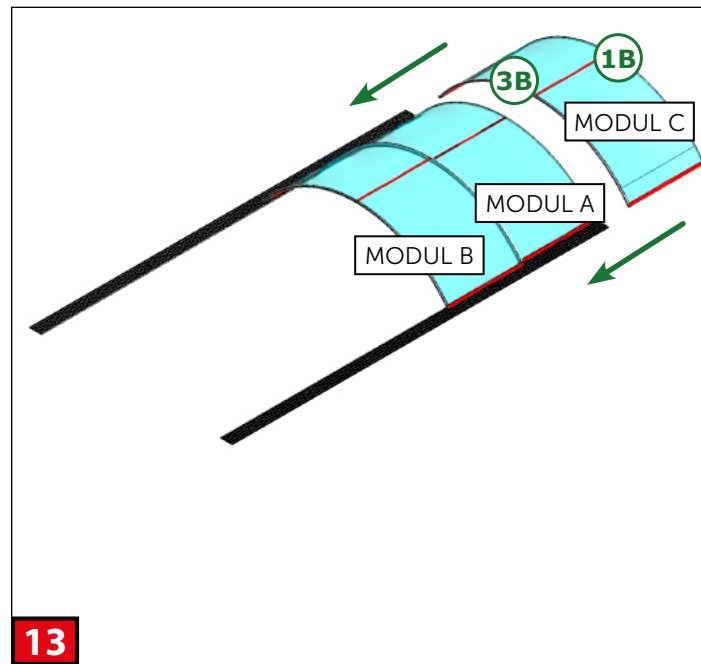
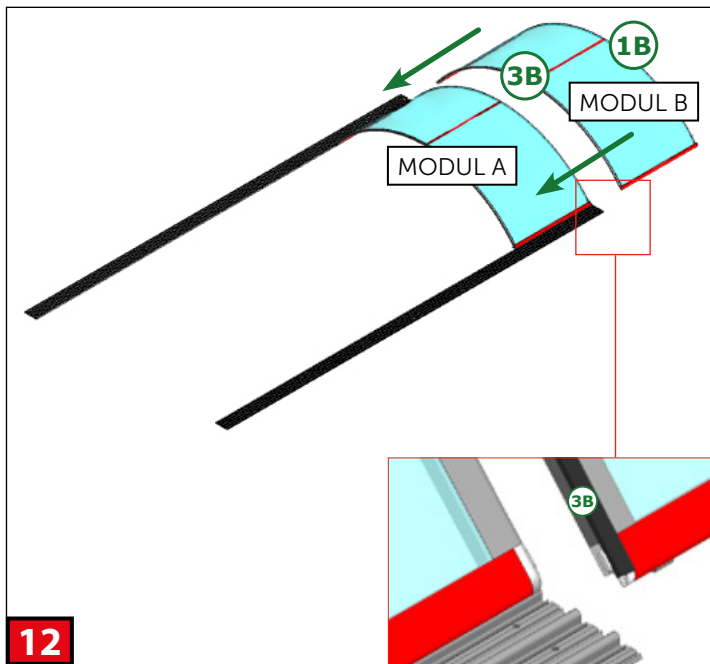

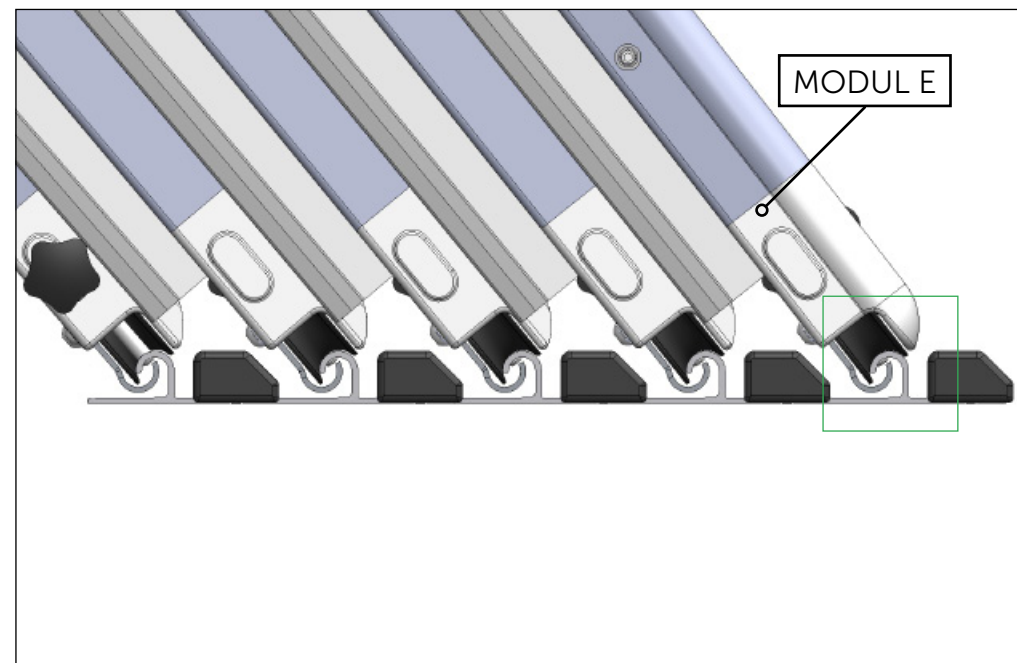
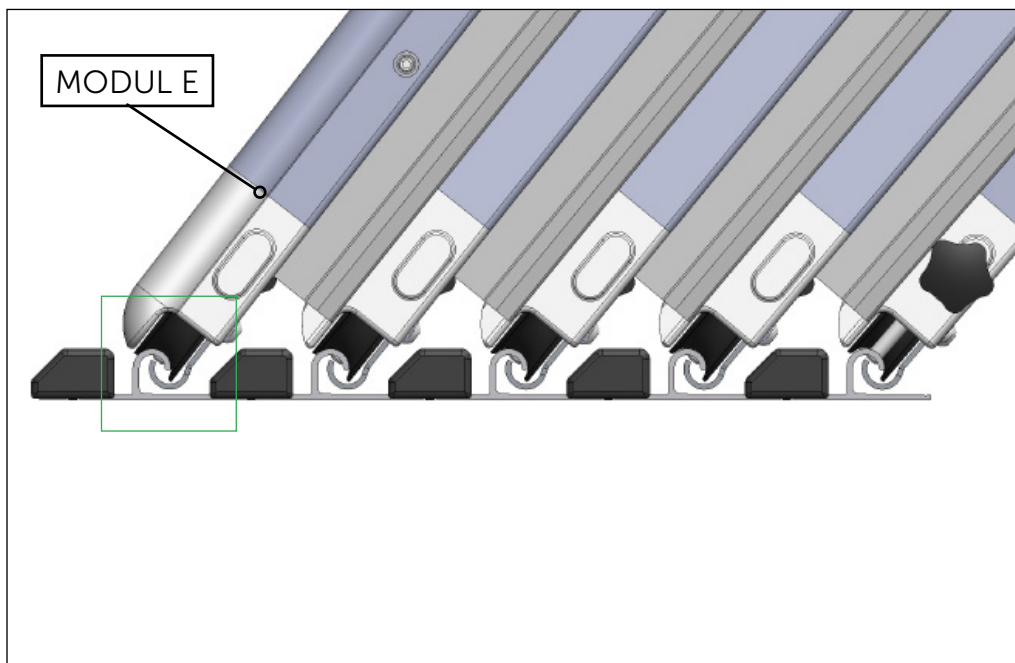
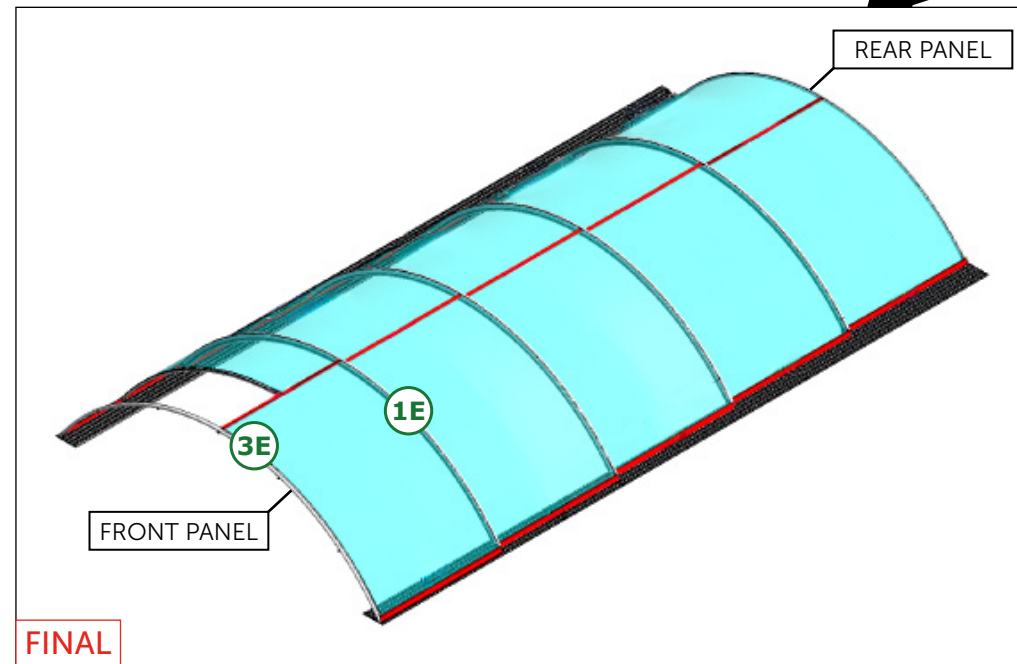
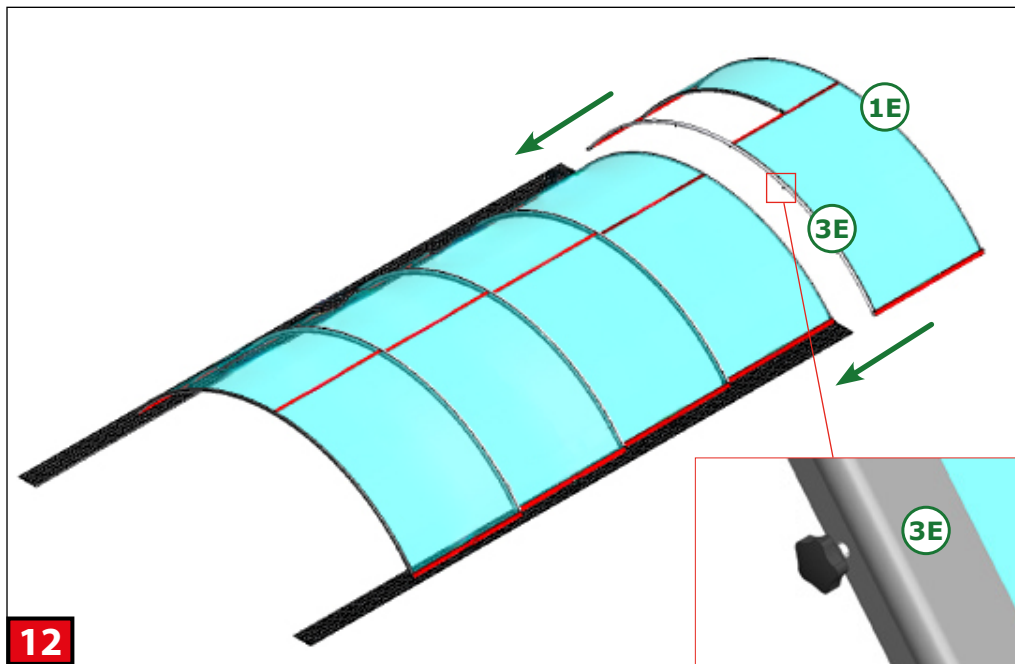

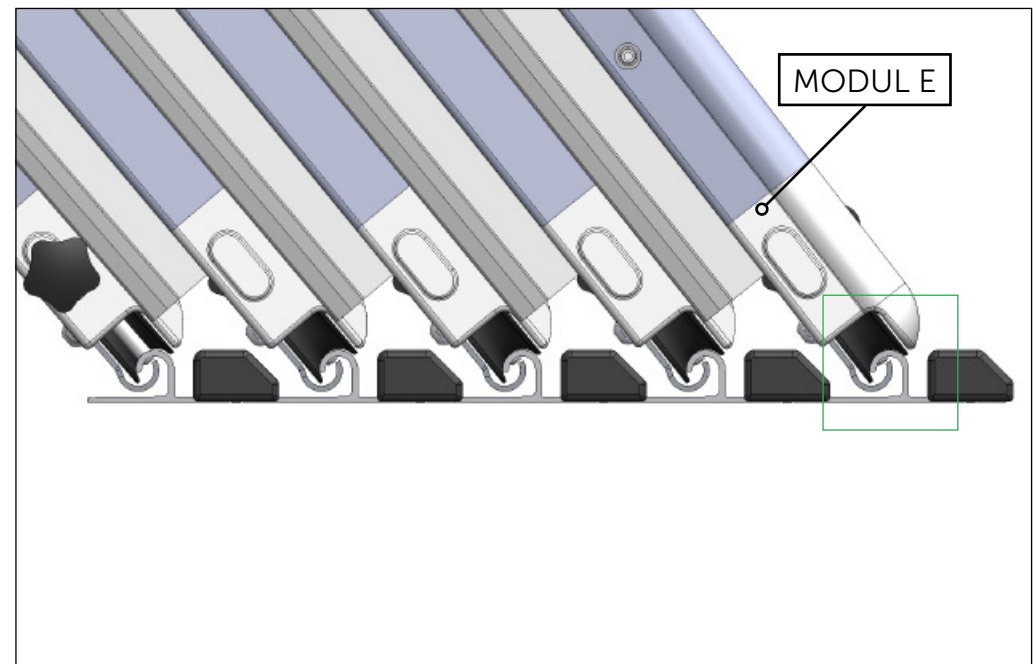
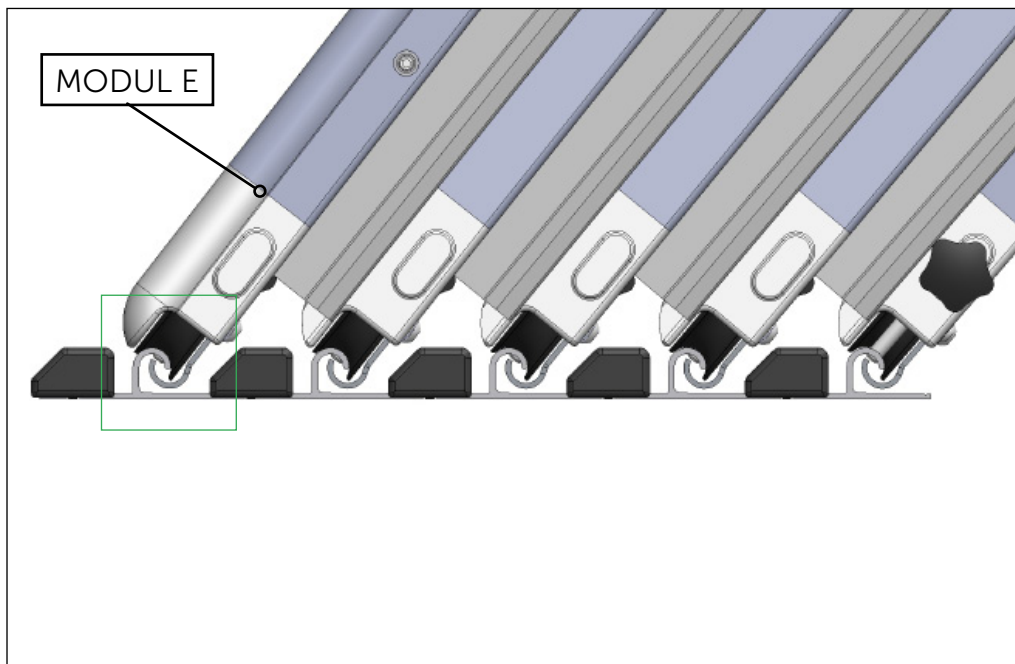
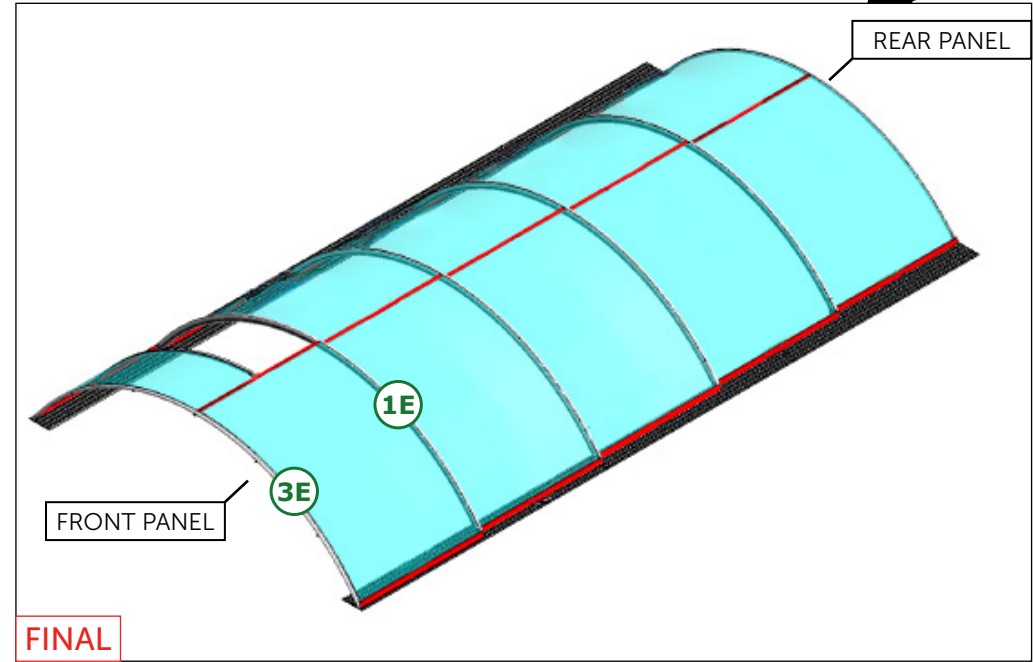
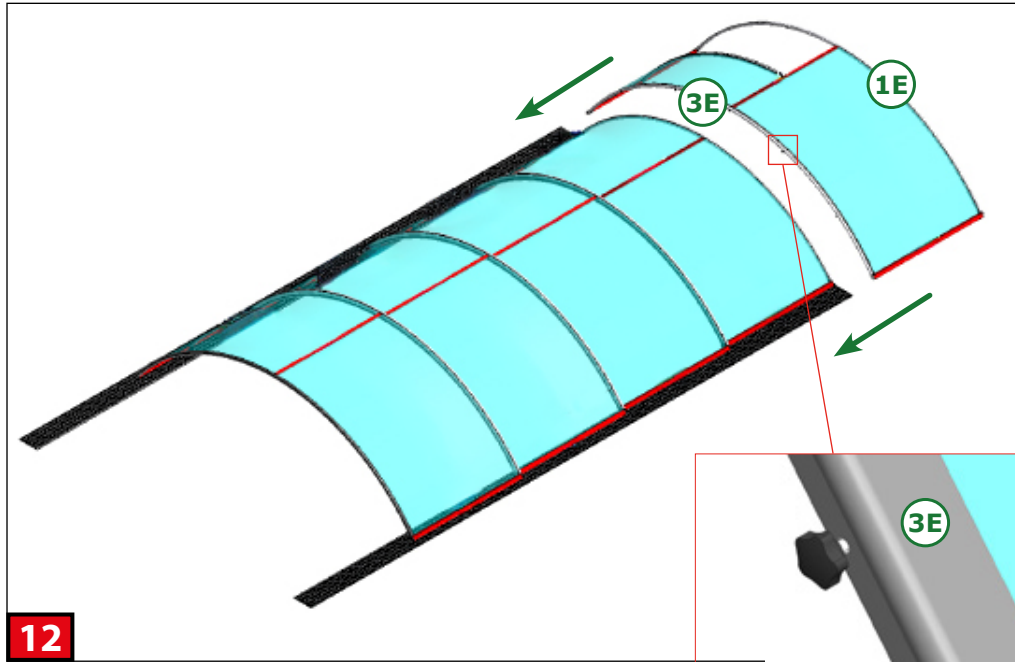

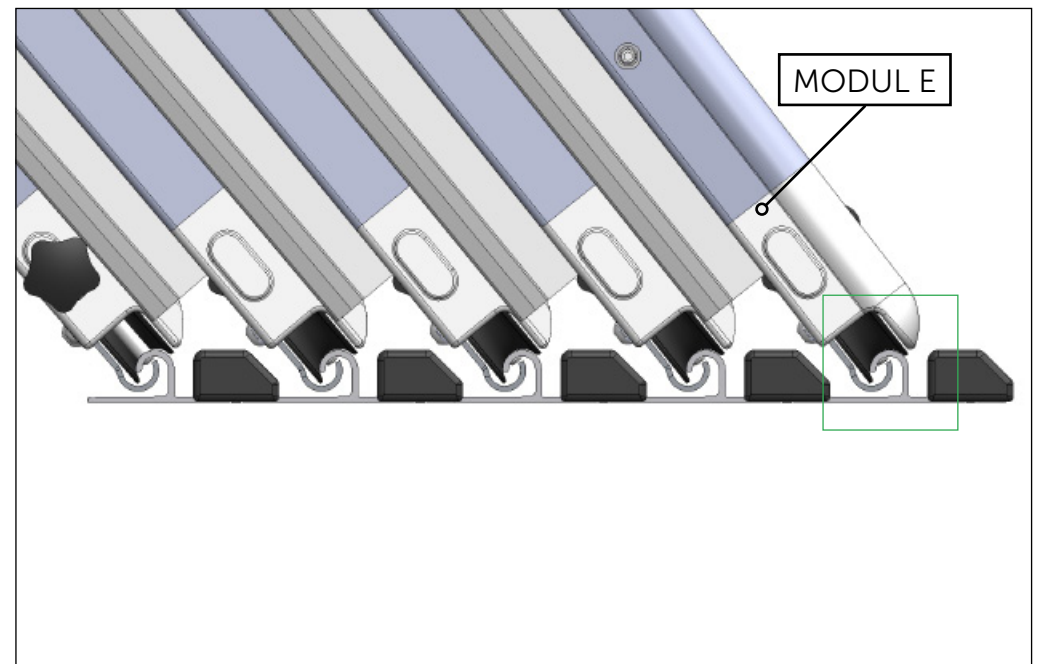
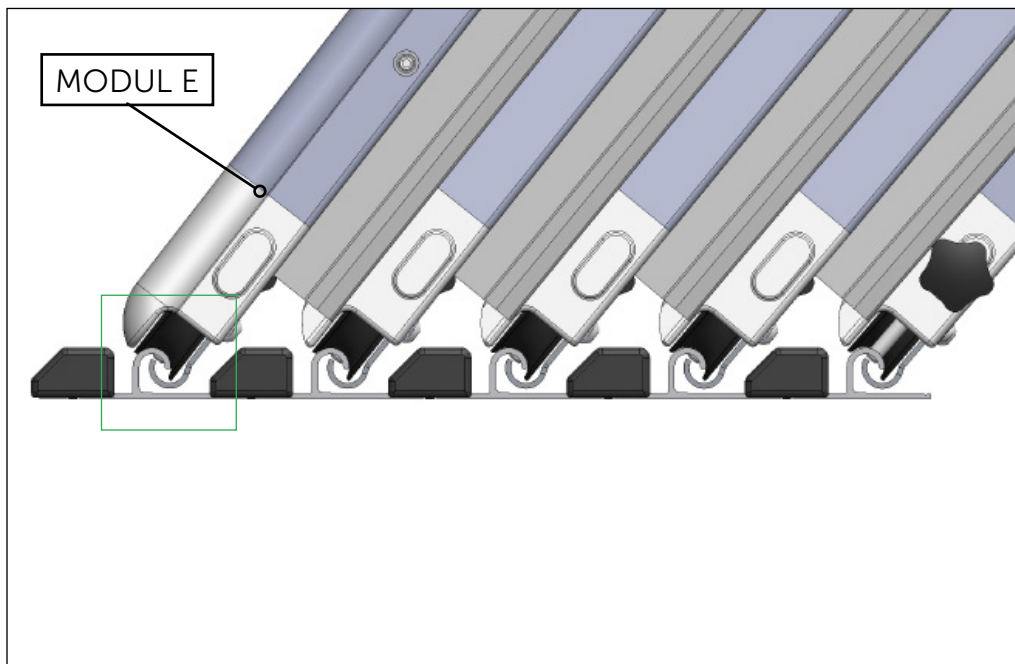
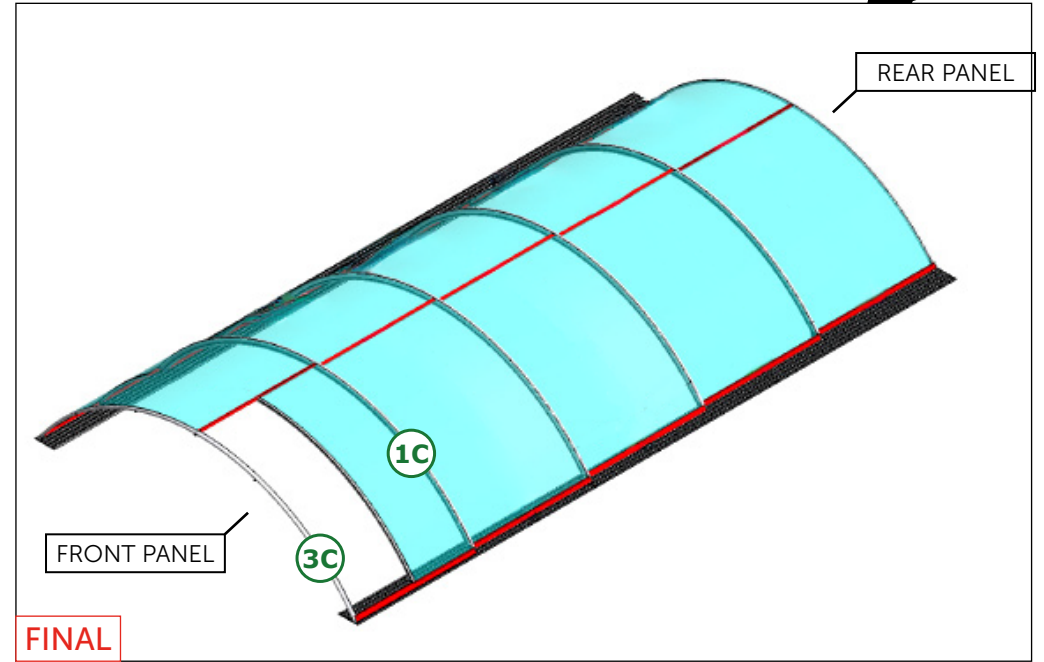
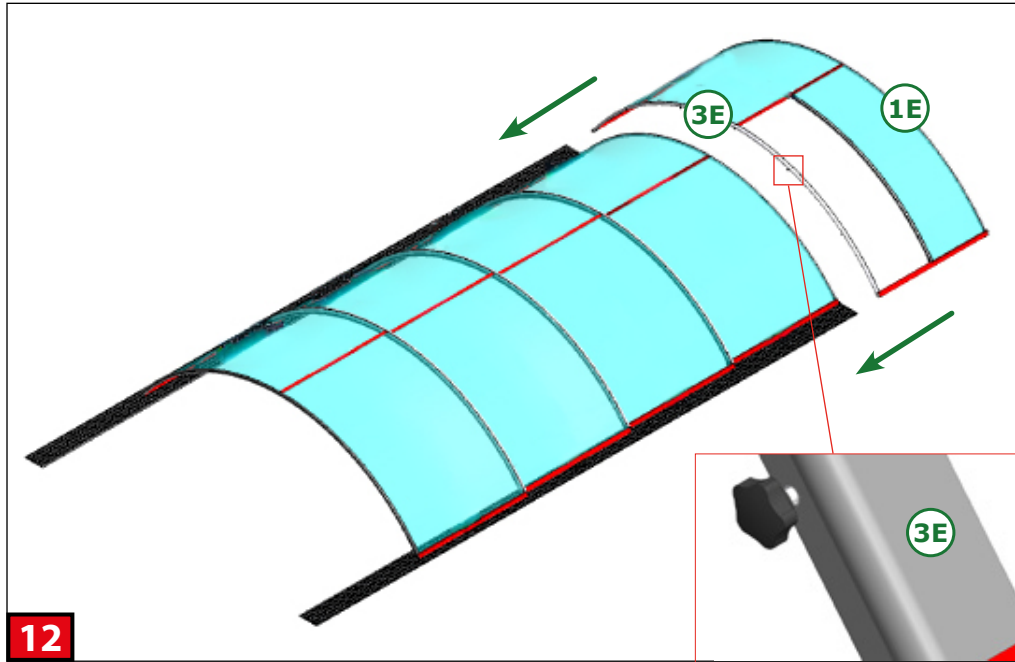

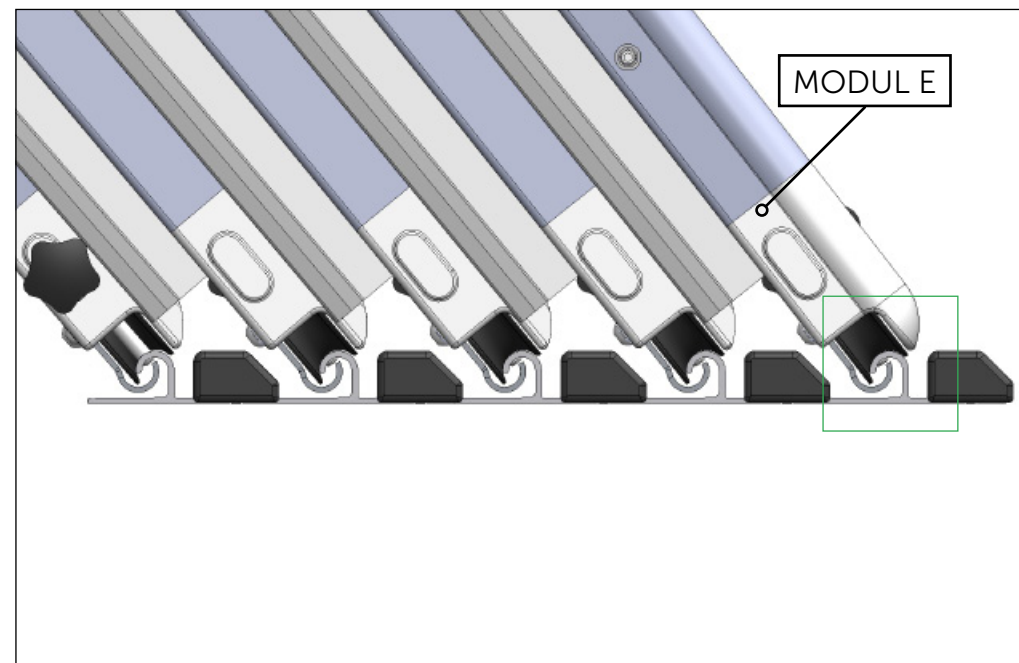
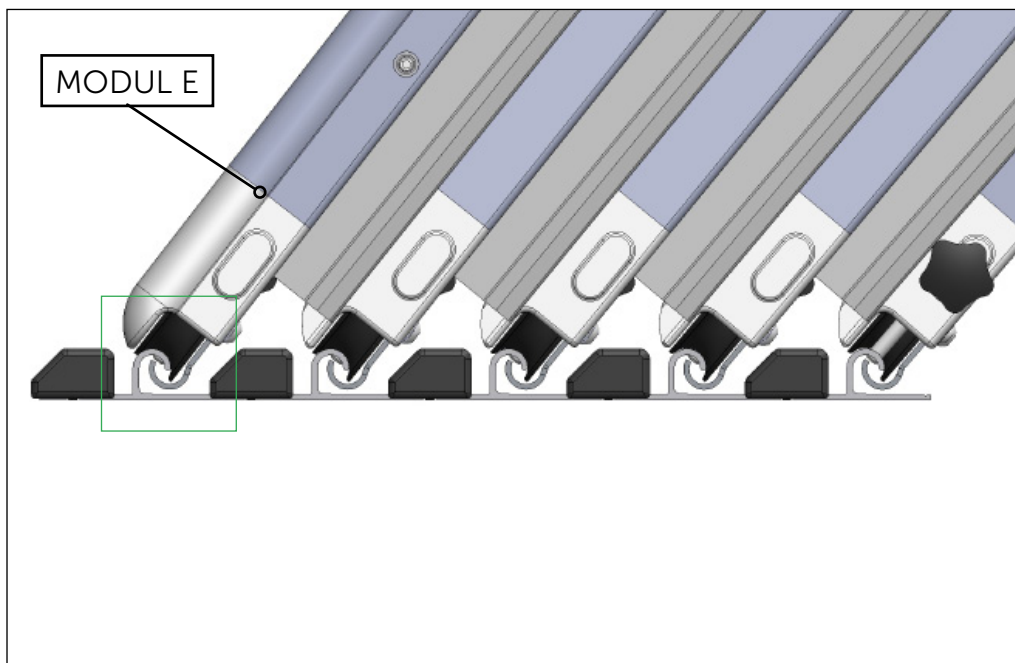
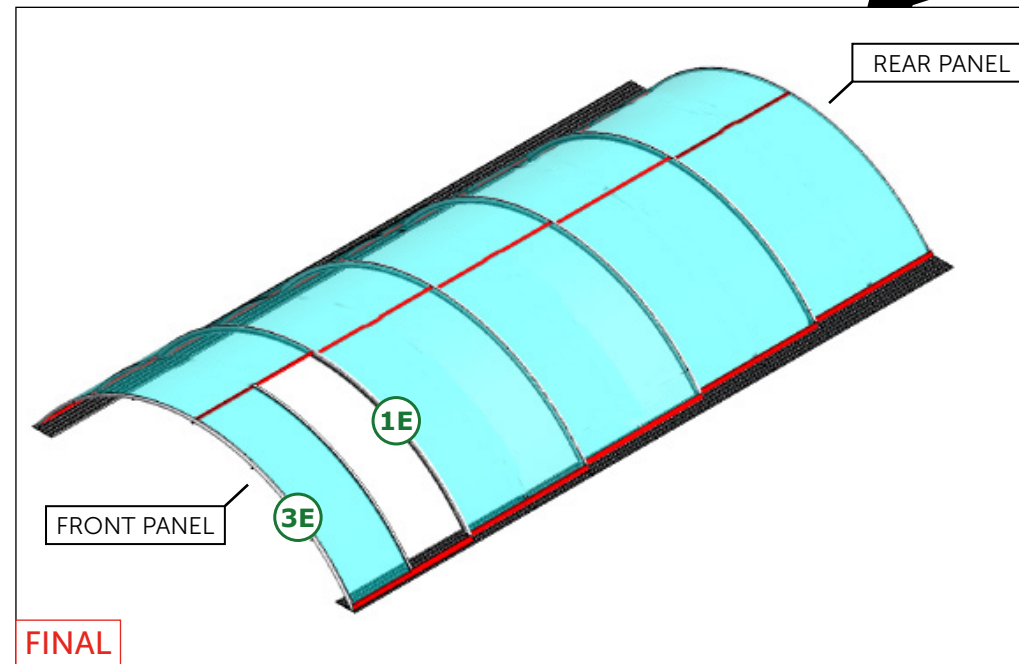
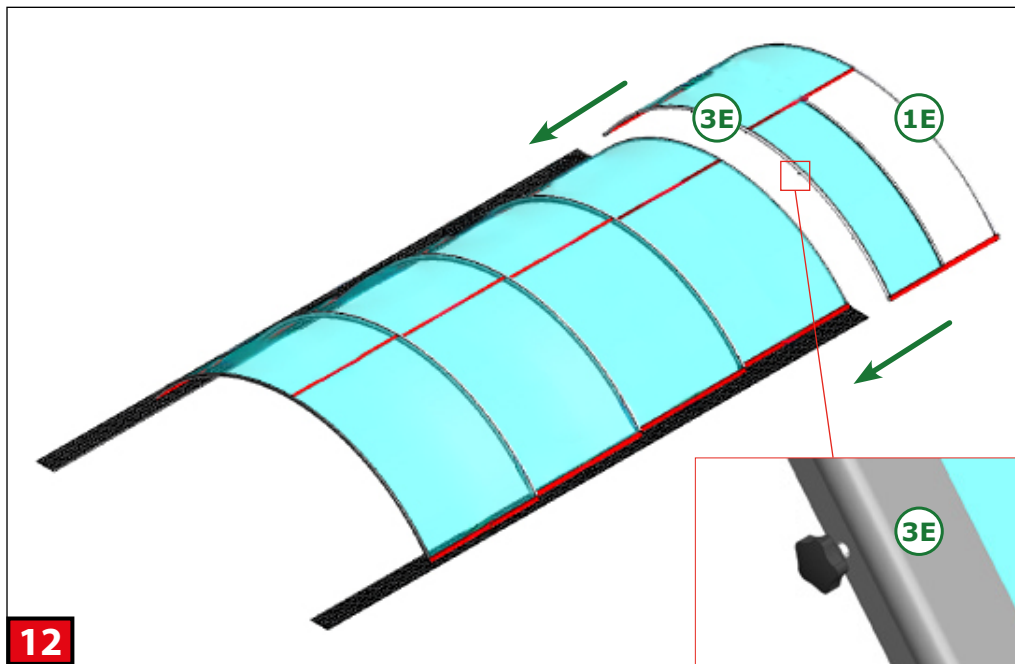

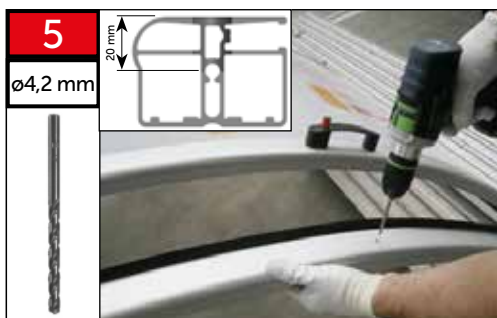

Před stlačením vždy vyndat klíček!
Remove the key before pressing the button!
Immer die taste entfernen, bevor sie drücken!
Avant de pousser toujours enlever la clé!!!!!!
Выньте ключ, прежде чем нажимать на кнопку!



Těsnění nastříhnout v místě tyčky madla.
Cut the sealing located in the handle rod.
Die gummidichtung an der stelle des stifts durchschneiden.
Découper le joint à l'endroit de la tige de poignée.
Разрезать уплотнение, расположенное в стержне рукоятки

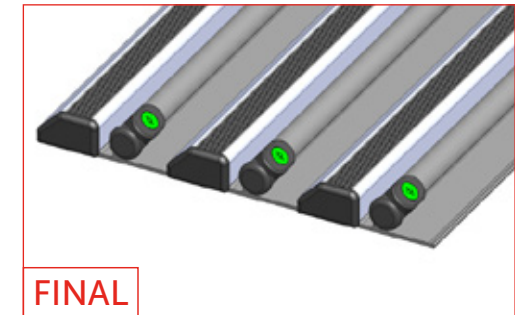
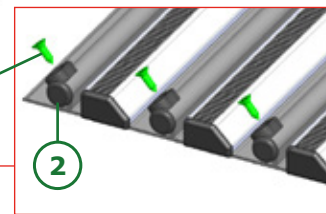
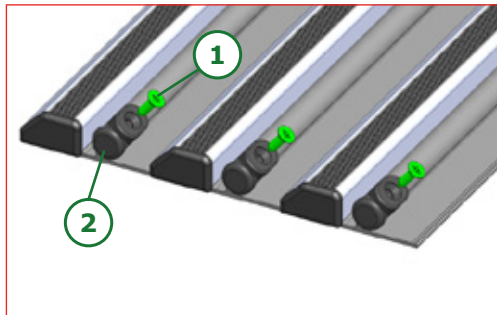
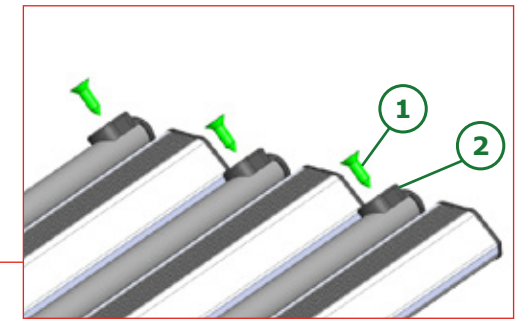
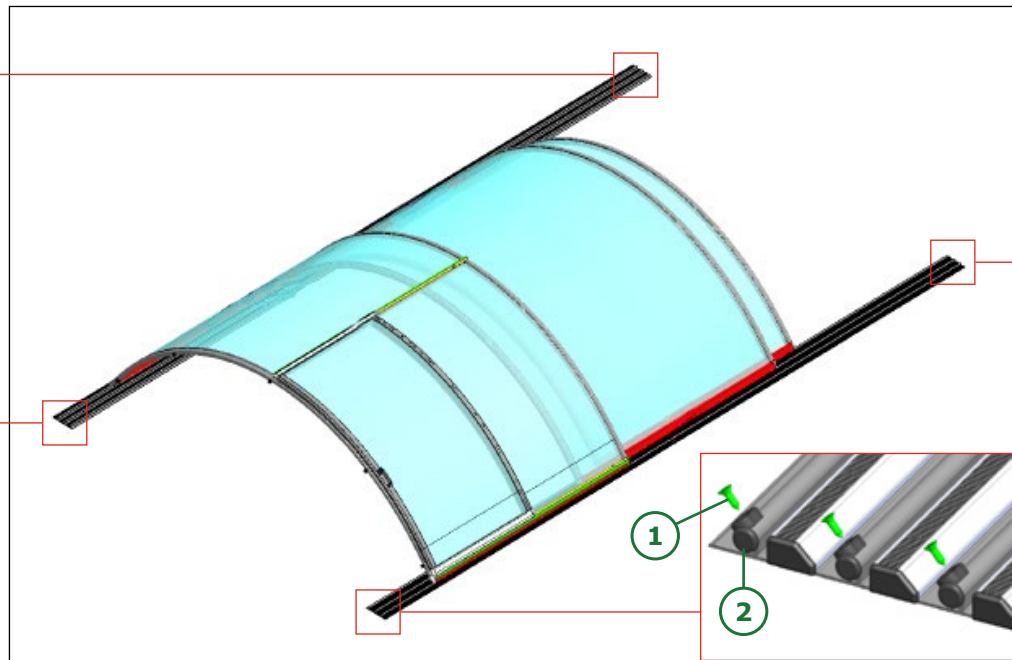
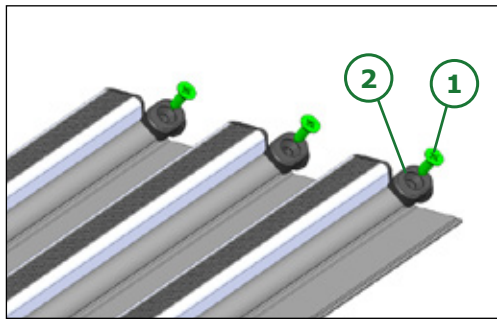
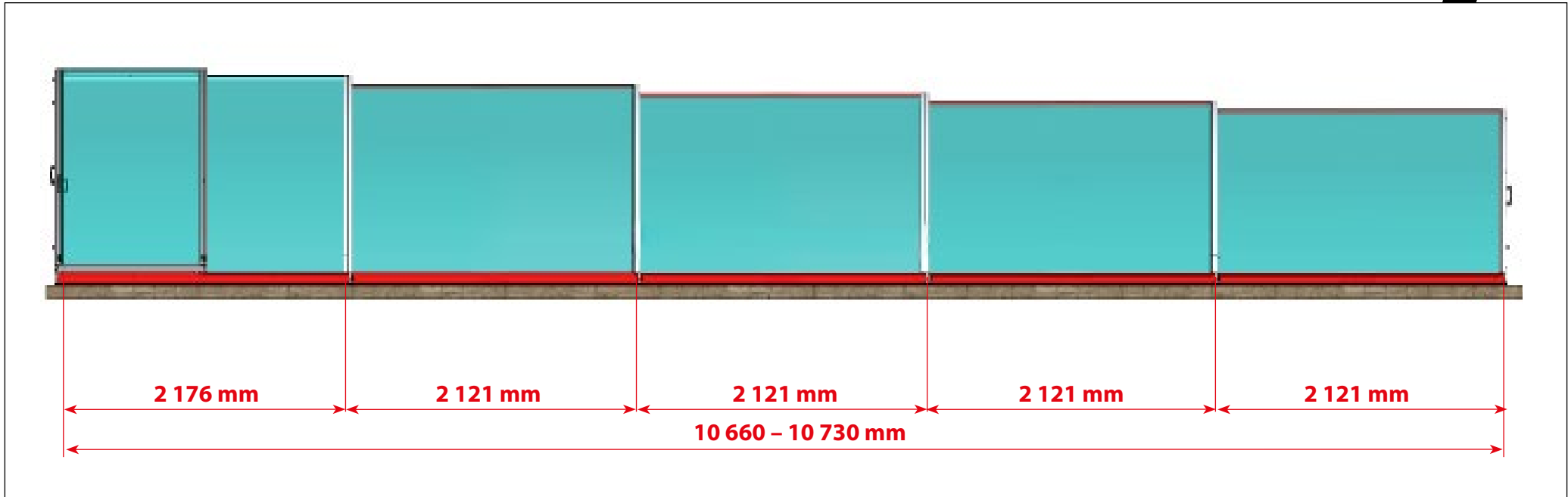

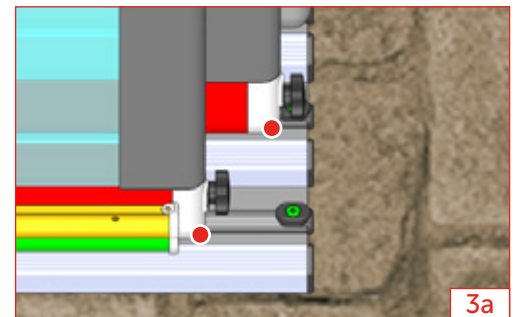
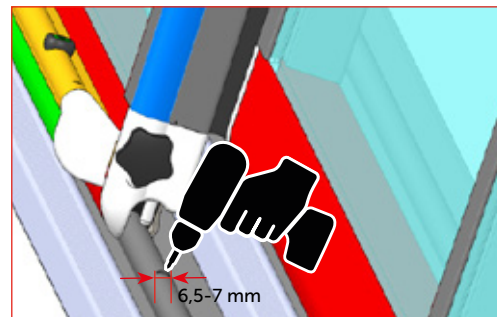
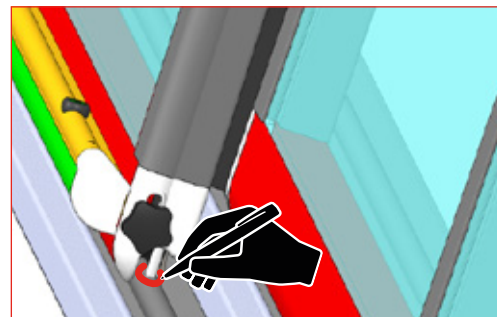
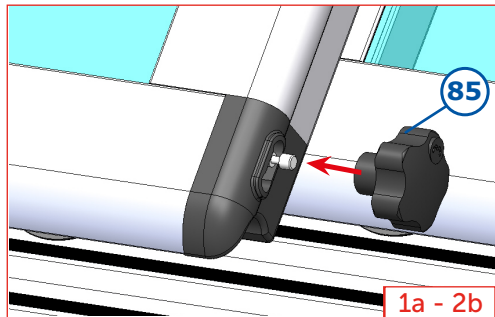
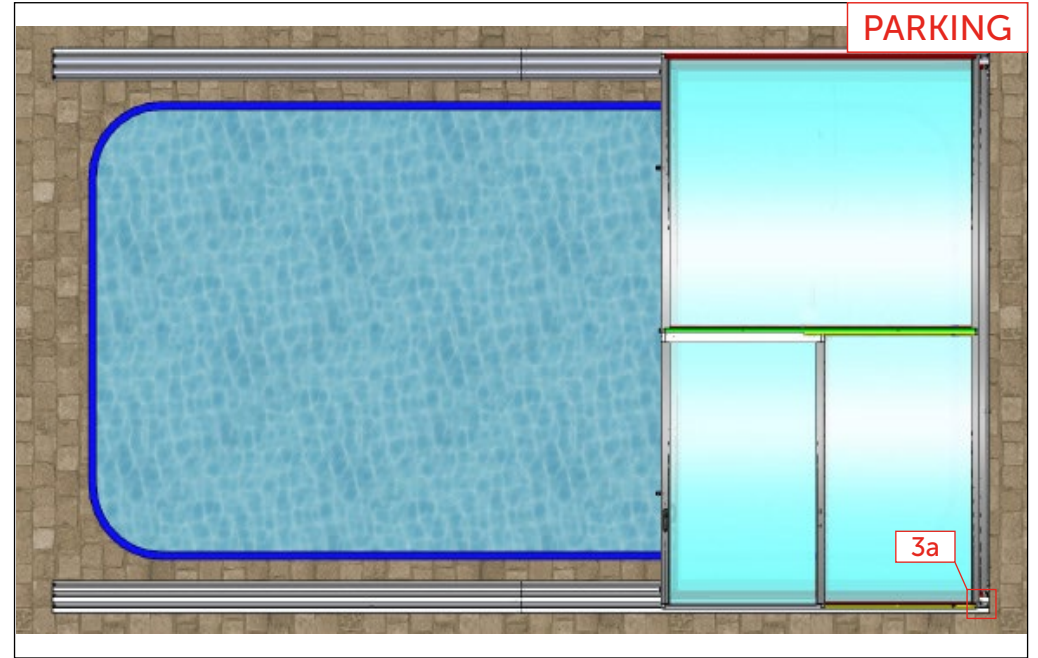
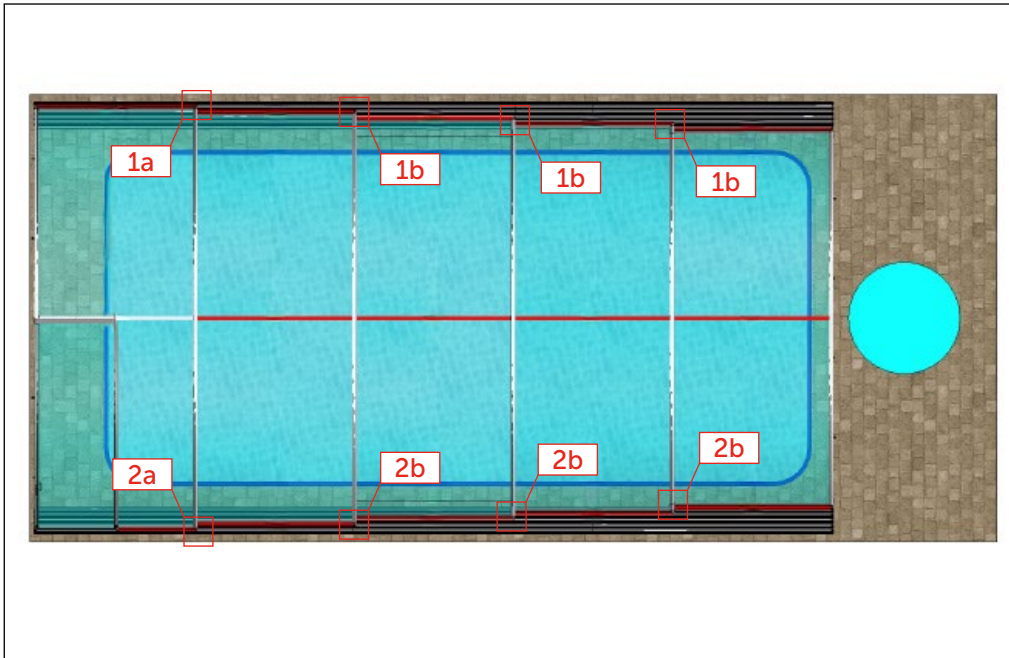
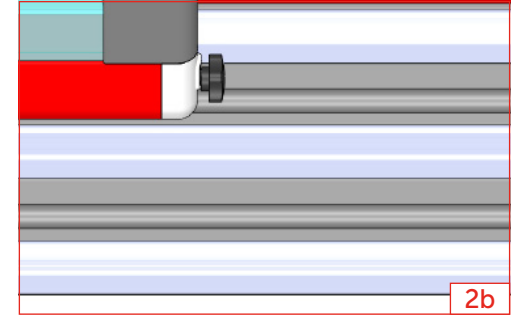
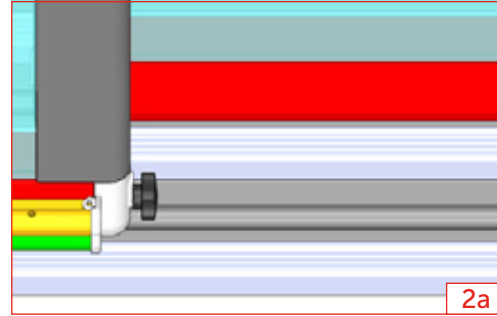
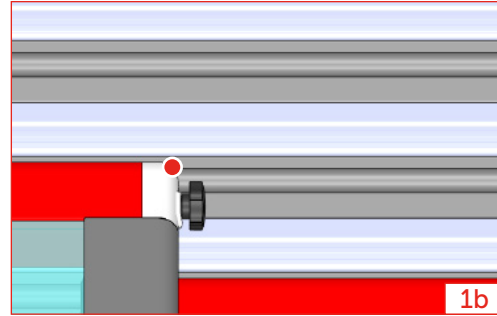
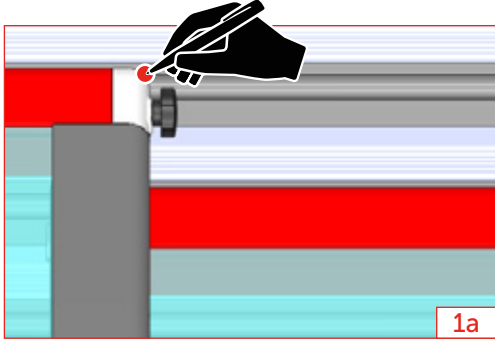

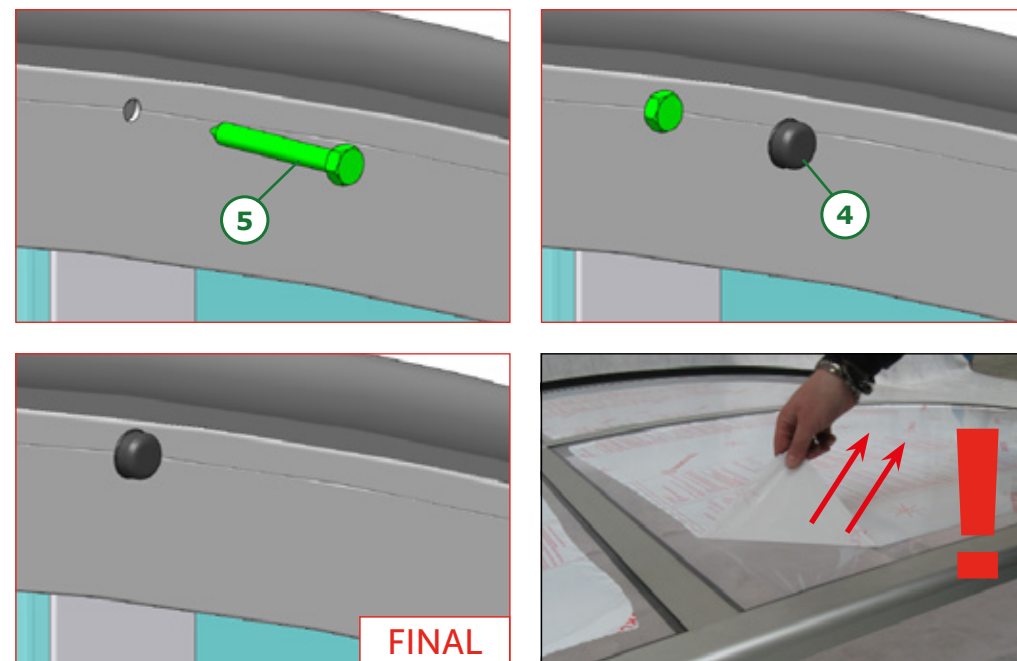
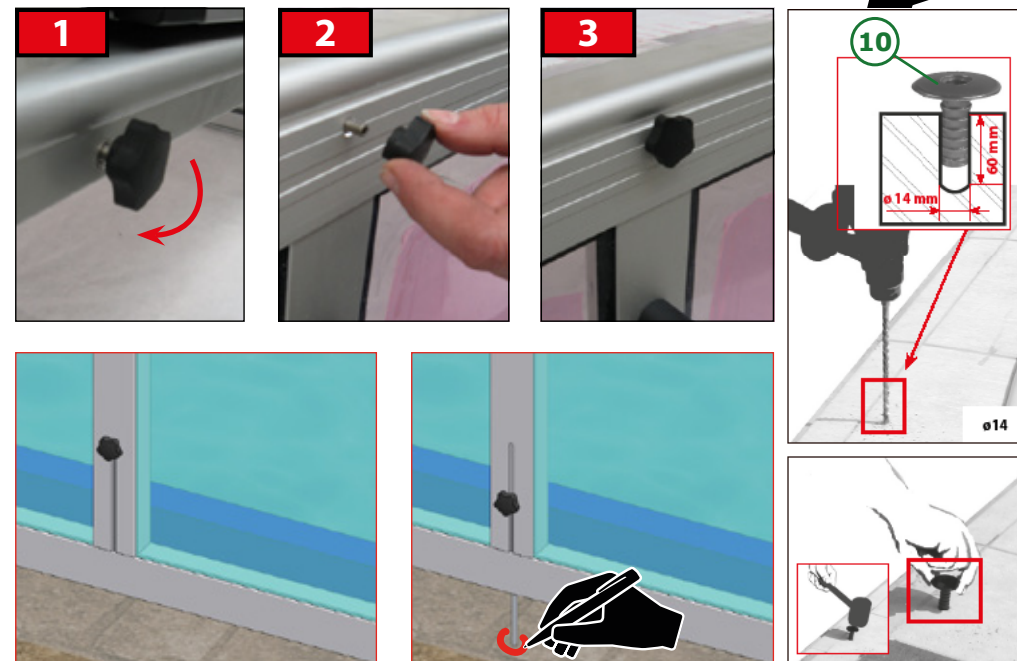
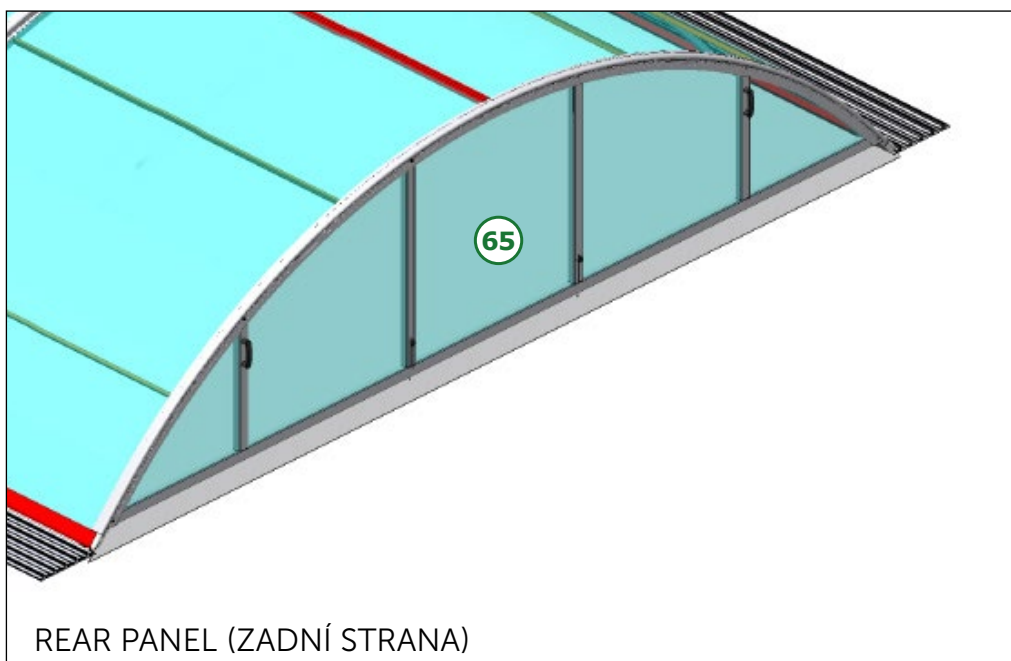
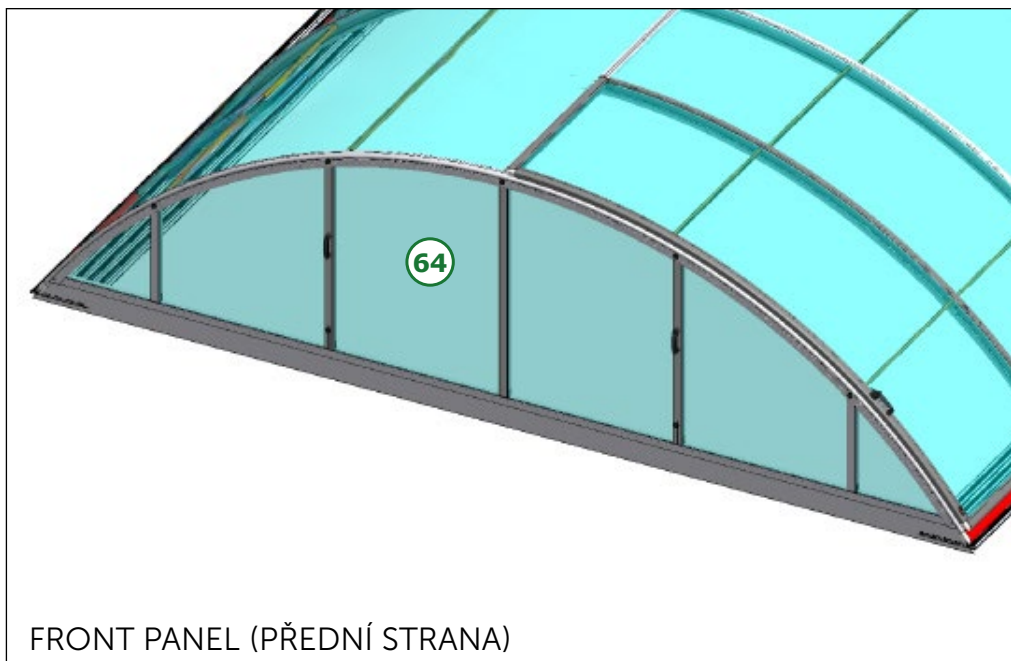

CZ

Dodavatel si vyhrazuje právo na změny a úpravy technických parametrů uváděných v tomto katalogu s ohledem na technický vývoj a zdokonalení výrobků a balení. Dodavatel si vyhrazuje právo na tiskové chyby a chyby v sazbě. Před montáží si pozorně přečtete návod. Návod si uchovejte pro pozdější použití. Tento produkt není považován jako stavební produkt.

DE

Der Lieferant behält sich das Recht auf Änderungen und Anpassungen der technischen Parameter, die in diesem Katalog aufgeführt sind, mit Rücksicht auf die technische Entwicklung und Verbesserung der Produkte und Verpackung vor. Der Lieferant behält sich das Recht auf Druckfehler und Fehler im Satz vor. Vor der Montage lesen Sie bitte die Anleitung sorgfältig durch. Bewahren Sie die Anleitung für spätere Verwendung auf. Dieses Produkt gilt nicht als Bauprodukt.

EN

The supplier reserves the right for modifications and adaptations of the technical parameters stated in this catalogue, considering the technical development and upgrade of the products and packaging. The supplier reserves the right for print errors and typographical errors. Please read the manual carefully before you will start the installation. Keep the manual for later use. This product is not considered a construction product.

ES

El proveedor se reserva el derecho de hacer cambios y modificaciones técnicas de los parámetros que figuran en este catálogo, con respecto al desarrollo técnico mejorando los productos y embalajes. El proveedor se reserva también el derecho a errores de impresión y composición. Antes de empezar la instalación, lea atentamente las instrucciones. Guarde las instrucciones para su uso posterior. Este producto no se considera un producto de construcción.

FR

Le fabricant se réserve le droit de modifier les paramètres techniques cités dans ce manuel en considération du développement technique et de l'amélioration des produits et de leur emballage. Le fabricant se réserve le droit des fautes d'impression et de composition. À lire attentivement et à conserver pour une consultation ultérieure. Ce produit n'est pas considéré comme un produit de construction.

HU

Gyártó fenntartja jogát a katalógusban feltüntetett műszaki paraméterek változtatására a termékek és csomagolás technikai fejlesztése és tökéletesítése szerint. Szállító: a szállító fenntartja jogát a nyomtatási és szedési hibákra. Ez a termék nem minősül építési terméknek.

IT

Il fornitore si riserva il diritto di effettuare modifiche e correzioni ai parametri tecnici riportati nel presente catalogo per migliorare e perfezionare dal punto di vista tecnico i prodotti e gli imballaggi. Il fornitore non esclude inoltre l'eventuale presenza di errori di stampa e di impaginazione. Prima dell'installazione, leggere attentamente le istruzioni. Tenere l'istruzione per un uso successivo. Questo prodotto non è considerato un prodotto da costruzione.

PL

Dostawca zastrzega sobie prawo do zmian oraz dostosowania parametrów technicznych podanych w niniejszym katalogu z uwzględnieniem rozwoju technicznego i udoskonalania produktów oraz opakowań. Dostawca zastrzega sobie prawo do błędów druku oraz typograficznych. Ten produkt nie jest uważany za produkt budowlany.

PT

O provedor reserva-se o direito a efectuar alterações e adaptações de parâmetros técnicos mencionados neste catálogo, tendo em consideração o avanço técnico e melhorias de produtos e embalagens. O provedor reserva-se o direito a cometer erros de impressora e de edição. Este produto não é considerado um produto de construção.

RO

Furnizorul își rezervă dreptul de a modifica și schimba parametrii tehnici menționați în acest catalog cu privire la evoluția tehnică și perfecționarea produselor și a ambalării. Furnizorul își rezervă dreptul la greșelile de tipar și greșelile privind tarifele. Acest produs nu este considerat produs de construcție.

RU

Поставщик оставляет за собой право на изменение и исправление технических параметров продукции указанной в этом каталоге, с учетом технического развития, а усовершенствования изделий и его упаковки. Поставщик оставляет за собой право на опечатку в тексте и в ценах. Перед установкой и эксплуатацией изделия внимательно ознакомьтесь с настоящим руководством. Сохраните данное руководство для дальнейшего использования. Этот продукт не считается строительным продуктом.